

EMULA

Dati Tecnici - Datasheet

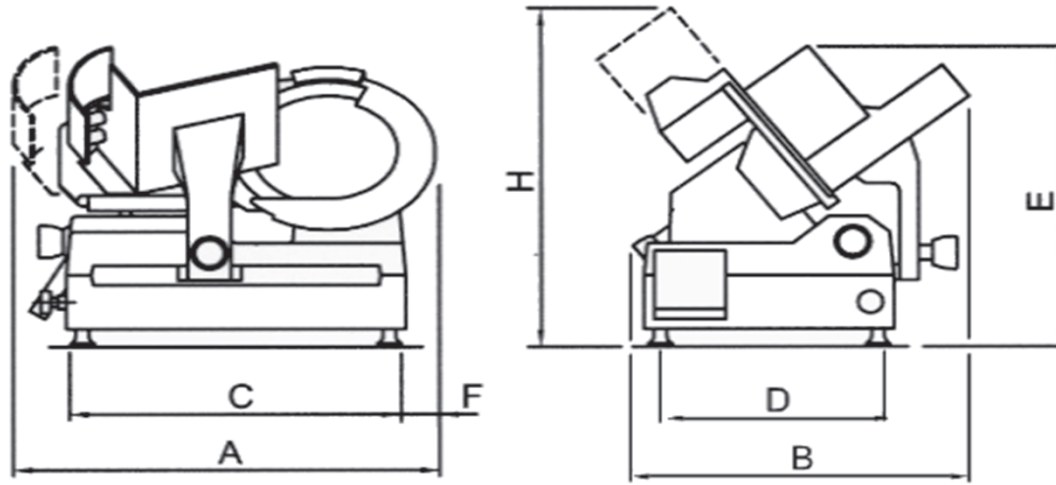

Modello <i>Model</i>	Diametro lama <i>Blade diameter</i>	Giri Lama <i>Blade revolution</i>	Motore monofase 230V/50Hz <i>Single-phase Motor</i>	Motore trifase 400V/50Hz <i>Three-phase Motor</i>	Corsa carrello <i>Run of carriage</i>	Spessore taglio <i>Cut thickness</i>	Capacità di taglio tondo <i>Round cut capacity</i>	Capacità di taglio HxL <i>Cut capacity HxW</i>	Peso netto <i>Net weight</i>	Dimensioni imballo <i>Shipping</i>	Peso lordo <i>Gross weight</i>	Dimensioni (mm) <i>Dimension (mm)</i>							
												A	B	C	D	E	F	H	
K-TGI300	300/11,8	270	264/0,35	275/0,37	310	0 - 14	215	190x250	50	74x68xh57+12	56+6	690	540	480	330	530	90	600	
K-TGI330	330/13,0	270	264/0,35	275/0,37	310	0 - 14	230	195x250	54	74x68xh57+12	60+6	690	540	480	330	545	90	615	
K-TGISP350	350/13,8	270	280/0,38	275/0,37	310	0 - 14	240	205x250	57	74x68xh57+12	62+6	690	540	480	330	560	90	620	